

CS7010

# Efficient large area cleaning

- at a lower total cost



# The CS7010 Hybrid and ePower combination sweeper

Suitable for warehouses, manufacturing plants, stadiums, universities, parking ramps and lots

- 1** ClearView sightlines and automatic speed reduction in turns for safer operation
- 2** High impact-absorbing polymer body panels won't dent, corrode or damage facilities.
- 3** Hybrid Drive backup battery power adds user convenience to drive to refueling station
- 4** High-capacity 198 litre front dry sweeper debris hopper with high-lift system
- 5** High performance Donaldson PowerCore® nanofiber filter with variable-frequency shaker
- 6** Heavy-gauge industrial steel unibody frame
- 7** Available with patented DustGuard™ airborne dust suppression technology
- 8** Standard dual side brooms sweep entire squeegee path to minimise fouling
- 9** Seat-accessible hopper safety prop rod



# weeper-scrubbers

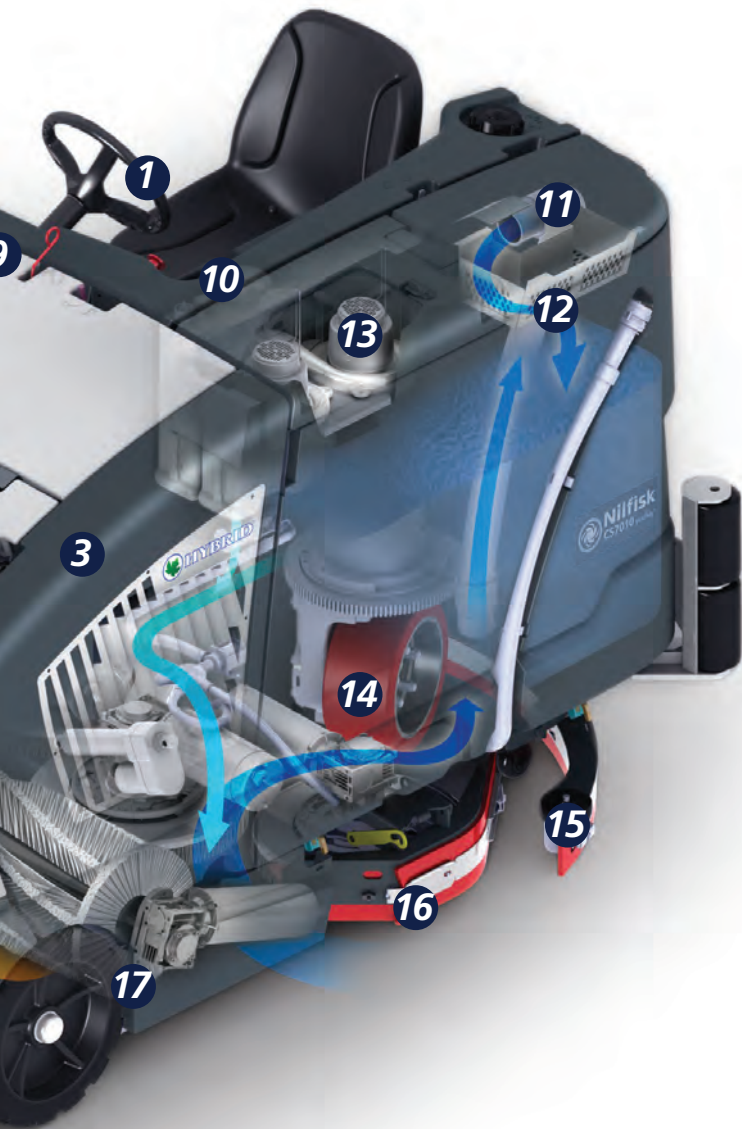

- 10** *Optional dual-tank EcoFlex™ System provides the most flexible cleaning solution for industrial applications*
- 11** *Tool-free tilt-out/lift-off recovery tank with integrated SmartFlow™*
- 12** *High-capacity 285 litre corrosion-proof solution and recovery tanks*
- 13** *Powerful dual vacuum motors deliver high waterlift and airflow to ensure a safe, dry floor*
- 14** *SmartFlow technology decreases water and chemical usage*
- 15** *Patented breakaway squeegee mechanism with tool-free servicing*
- 16** *Disc scrub deck with integrated, powerful edge cleaning capability*
- 17** *Brushes, brooms and squeegee can be replaced without tools*
- 18** *Electronically-controlled electric drives are IP55 rated for easy cleaning and reliable operation*

# More effective cleaning

## DustGuard™



Patented DustGuard™ is proven to reduce airborne dust generated by side broom sweeping. An ultra fine fog suppresses fugitive dust

## EcoFlex™ System



EcoFlex™ System with interchangeable dual detergent cartridges are refillable with your favorite brand of detergents

## UltraWeb® Nanofilter

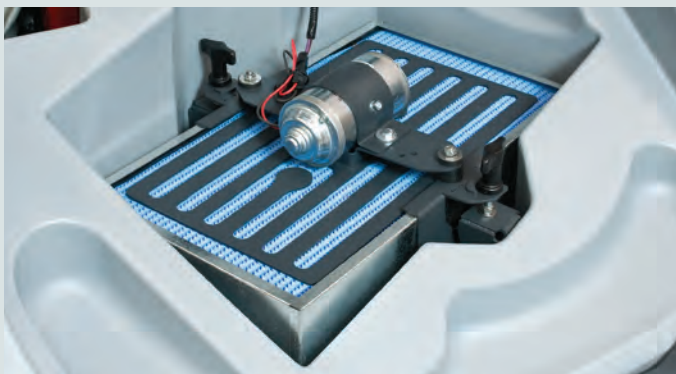

High-capacity Donaldson PowerCore® UltraWeb® nanofilter synthetic media filter with MERV 13 rating with a variable-frequency shaker. Provides superior dust/dirt holding capacity in a more compact package for longer filter life and improved dust control compared to conventional pleated filters

## HYBRID Technology



The CS7010 delivers unparalleled performance, while replacing power-hungry, high-maintenance hydraulic systems with efficient, state-of-the-art Electric Drive technology

## Intuitive Control Panel



Intuitive controls with OneTouch™ operation reduces training time, improves productivity and delivers more consistent cleaning results

## SmartFlow™



SmartFlow™ adjusts solution flow with the machine's speed, using water and chemicals. Proportionally higher productivity with fewer dump and refill cycles per tankful

# Simpler cleaning

## Pivoting Scrub Deck



Retractable 10 cm offset disc deck enhances edge scrubbing and resists damage from accidental impact

## MaxAccess™

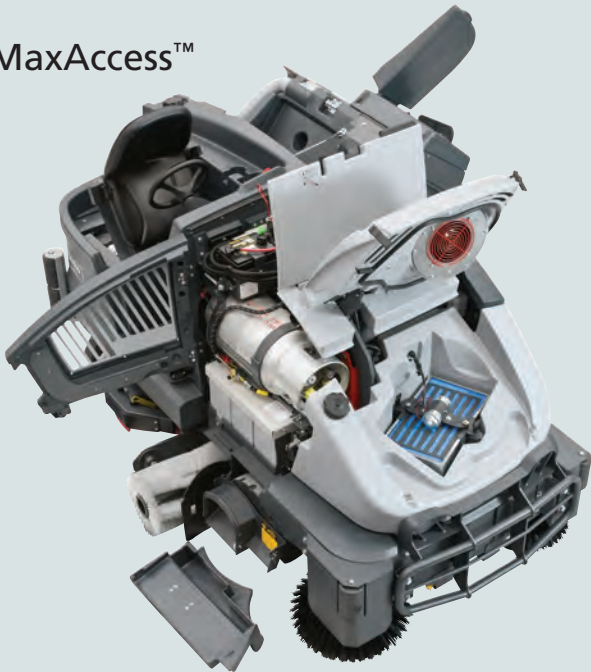

We designed the CS7010 to provide quick access to all vital systems for easier inspection and maintenance

# Safer cleaning

## Speed reduction



Automatic speed reduction in turns for improved safety and reduced risk of impact damage

## Ergonomic operator compartment



The CS7010 has a fully adjustable seat and tilt steering



## Kubota® Industrial Engine

- Rugged industrial engine design offering superior operating life
- Best in industry quiet operation
- Gear-driven valve train eliminates timing belts or chains, improving reliability and reducing maintenance costs

## Technical specifications

Models	CS7010 Battery	CS7010 LPG/Gas Hybrid	CS7010 Diesel Hybrid
Configuration	Independent front dry sweeping w/dust control and rear scrubbing functions Electronically controlled electric drives for all sweeping and scrubbing functions Electrically driven hydraulic power unit for hopper raise/lower functions		
<b>Sweeping System</b>			
Sweeping Path w/Dual Side Brooms	154 cm - Squeegee path width is fully swept		
Main Broom	90 cm x 31 cm		
Sweeping Coverage Rate Per Hour	13,600 m <sup>2</sup>		
Dust Control System	10,7 m <sup>2</sup> Donaldson high-capacity PowerCore® UltraWeb® filter w/synthetic media. Variable frequency automatic filter shaker		
Hopper Dump Height (Max.)	152 cm		
Hopper Capacity	198 liter 136 kg		
DustGuard™ Tank Capacity <sup>1</sup>	110 liter		
<b>Scrubbing and Recovery Systems</b>			
Scrubbing Path and Brushes	165 cm - 3 x 43 cm disc		
Scrubbing Coverage Rate Per Hour	11,000 m <sup>2</sup>		
Scrub Pressure	Three scrub pressure settings up to 182 kg of down force at maximum setting		
Recovery/Solution Tank Capacity	285 liter each		
Recovery Vacuum	Dual vac fan motors capable of 165 cm waterlift		
<b>Power and Propulsion Systems</b>			
Power System	Battery: 36 V/770 Ah	Kubota WG972: 3 cyl., 0,96 liter 30 hp (22.0 kW)	Kubota D1305 <sup>3</sup> : 3 cyl., 1,26 liter 29 hp (21.7 kW)
Propulsion System	Variable speed brushless A/C drive		
Propel Speed (Variable) Transport	8,9 km/h		
Sweeping/Scrubbing	5,6 km/h w/override capability		
Operational Run Time Sweeping/Scrubbing <sup>2</sup>	5.4 hrs. w/770 Ah battery	LPG - 5.5 hrs. w/14.5 kg tank Gas - 5.9 hrs. w/35 liter tank	15 hrs. w/35 liter tank
Gradeability Transport @ Gross Weight	21% (12 deg.)		
Scrubbing/Sweeping	17.6% (10 deg.)		
<b>Dimensions/Weight/Sound/Environmental</b>			
Length	262 cm		
Width	165 cm		
Height	[150 cm] [208 cm std. overhead guard] [201 cm low clearance overhead guard]		
Minimum Aisle Turn	264 cm		
Weight : GVW	2,593 kg	2,121 kg	2,058 kg
Empty	2,124 kg	1,649 kg	1,593 kg
Sound Level (IEC60335-2-72)	72 dB(A)	82 dB(A)	81 dB(A)
Water Ingression	All electric drive motors and actuators rated IP55 for water washdown		

Specifications are subject to change without notice.



<sup>1</sup> DustGuard™ optional

<sup>2</sup> Measured run time using low scrubbing and sweeping mode at normal operating speeds on smooth floors (actual results will be application dependent)

<sup>3</sup> Meets EPA emission standards under 40 CFR 1039.625

CS7010 models shown in photos may feature optional accessories

### Nilfisk Ltd

Nilfisk House, Bowerbank Way, Gilwilly Industrial Estate, Penrith, Cumbria, CA11 9BQ  
Tel.: 01768 868995 (UK), 01 2943838 (IE)  
Email: mail.uk@nilfisk.com (UK), info.ie@nilfisk.com (IE)  
www.nilfisk.co.uk, www.nilfisk.ie

